

Operating Instructions Electric Motors Size 56 - 400



Table of contents	2
1. Safety instructions.....	3
1.1. Validity.....	3
1.2. Qualification of the personnel.....	3
1.3. Basic safety rules	3
1.4. Electrical potential.....	3
1.5. Mechanical movement.....	4
1.6. Increased surface temperatures	4
1.7. Noise emission.....	4
2. Proper use	4
2.1. Unauthorized usage	5
2.2. EU Motor regulation VO (EG) No. 640 / 2009	5
3. Transport und storage	5
4. Installation and assembly.....	6
5. Electrical connection	6
5.1. General information	6
5.2. Connection of lead out cables.....	7
6. Commissioning	7
6.1. General information.....	7
6.2. Tightening torques	8
7. Maintenance.....	9
7.1. Initial inspection	10
7.2. Main inspection	10
7.3. Lubrication.....	11-12
7.3.1 Bearing sizes IP23 motors.....	12
8. Auxiliary equipment	13
8.1. Thermal protection.....	13
8.2. Electromagnetic compatibility	13
9. Troubleshooting	14
10. Structure of the motors.....	15-18
11. Connection variants + circuit diagrams.....	19
11.1. Three phase motor.....	19
11.2. Forced cooling fan.....	20
11.3. Brake motor brake rectifier.....	21
11.4. Pole-changing motors.....	22
12. Motor behavior in frequency inverter operation.....	23
12.1. Explanation of the 87 Hertz characteristic curve.....	23
13. Declaration of Conformity.....	24

1. Safety instructions

Please read the operating manual carefully before you start with commissioning. Consider the following warnings to avoid personnel injuries and machinery failures. JS-Technik GmbH assumes no responsibility or guarantee for damage and consequential damage caused by failure to observe the operating instructions.

1.1. Validity

These operating instructions are only valid for the following low-voltage three-phase motors (for AC motors, brakemotors, motors with frequency inverters and ATEX motors there are special operating and maintenance instructions from JS-Technik):
Series: MS, MX, MX2, MX3, ML, KSD, KSE

1.2. Qualification of the personnel

All work on transport, connection for commissioning, and regular maintenance must be conducted by suitable, qualified, instructed, and authorised personnel. (VDE 0105; please observe IEC 364).

1.3. Basic safety rules

The safety risks posed by the motor must be reassessed after installing it into the end device. The local occupational safety regulations must be observed during the usage of the motor. The operation place must be kept clean and tidy.

1.4. Electric Voltage

Regularly check the electrical equipment of the motor. Immediately replace loose connections and defected cables. To avoid electrical shock, use a rubber mat while working on the electrically charged motor.



DANGER

Electric charge on the motor

Do not open the terminal box until five minutes after the voltage supply has been switched off.



DANGER Voltage can occur at the terminals even when the motor is switched off

Do not stay in the danger zone of the motor. When working on the motor, switch off the mains voltage and secure it against being switched on again.



DANGER

Motor restart

If the control voltage is applied or the speed setpoint is stored, the motor restarts automatically after a power failure.

1.5. Mechanical movement

Body parts which come into contact with rotating parts, can be injured. Clothes, jewellery, and similar objects can be caught and pulled into the motor. Secure the motor against contact. Do not wear loose garments while working on the motor. A test run must be performed without a key (risk of centrifuging).



DANGER

Rotating parts

1.6. Increased surface temperatures

Ensure sufficient contact protection to avoid burn risks.



DANGER

Surface temperatures

1.7. Noise emission

Take protection measures and secure the personnel with appropriate equipment, such as hearing protection.



DANGER

Sound pressure level

2. Proper use

The motors are only approved by JS-Technik GmbH for being used for purposes specified in the catalog and related technical documentation. Any other usage beyond this is not permitted. This also includes the consideration of all related product regulations. Modifications to the motor are not permitted. Other products and components which are being used with or integrated to the motor must be approved by JS-Technik GmbH. The usage in EX-area is prohibited, unless explicitly designated for this purpose (note additional information).

2.1. Unauthorised usage

In particular, the following uses of motors are prohibited and can lead to machinery failure:

- Operating the motor with imbalance, for example, caused by dust deposits or icing.
- Resonance operation, operation with strong vibrations, transmitted from the environment to the motor. Periodic shock impacts only up to 1G are permissible. For the higher shock loads contact JS-Technik GmbH.
- Painting of the motors (if not explicitly approved by JS-Technik GmbH).
- Release connections, for example, screws during operation.
- Opening the terminal box during operation.
- Operating the motors near combustible materials or components.
- Operating the motors in an explosive atmosphere.
- Operation with fully or partially dismantled or manipulated devices.

2.2. EU Motor regulation (EU) 2049/1781

As of Oct. 1, 2019, the European Commission's Regulation (EU) 2049/1781 for electric motors has come into force. In this regulation, the ecodesign requirements for 2-, 4-, 6-, and 8-pole low-voltage three-phase asynchronous motors in the power range 0.12 kW to 1000 kW are regulated. Extensive changes must be complied with from 1 July 2021.

Reorganization of the classification of energy-efficient asynchronous motors
Regulation(EU)2049/1781 of 1.10.2019

Motor type	Minimum requirement for energy efficiency					
	2020	2021	July 2021	2022	2023	July 2023
AC motors Induction motors up to 1000V						
0,75-7,5 KW 3 phase, 2/4/6 pole	IE2+VFD/IE3		IE3			
7,5-375 KW 3 phase, 2/4/6 pole	IE2+VFD/IE3		IE3			
75-200 KW 3 phase, 2/4/6 pole						IE4
375-1000 KW 3 phase, 2/4/6 pole			IE3			
0,75-1000 KW 3 phase, 8 pole			IE3			
0,75-1000 KW ATEX (except eb*) and brake motors			IE3			
0,12-1000 KW EX eb* 2/4/6/8 pole						IE2
≥ 0,12 KW 1 phase						IE2
0,12-0,75 KW 3 phase, 2/4/6/8 pole			IE2			

*EX eb: Motor with increased safety

3. Transport und storage

Keep the motors safe against mechanical damage and only in closed dry rooms. In case of short-term storage in an open air area the motors must be protected against harmful environmental influences. Motors must not be transported and stored on the fan cover. For transport the eye bolts of motors must be used with suitable lifting devices. The eye bolts are only intended for lifting the motor without additional attachments such as base plates, gear boxes etc. If the eye bolt is removed after installation, the openings must be permanently closed according to the type of protection.

For longer storage periods, a low vibration environment should be ensured to avoid bearing damage. After a storage period or downtime period of more than 12 months, a check of the grease state of all lubricated parts, such as bearings and shaft seal rings, must be carried out before commissioning and, if necessary, the grease must be replaced.

Caution: for longer storage or downtime periods a check of bearings and oil seals must be conducted before commissioning.

4. Installation and assembly

The following points must be observed during installation and assembly:

- Ensure even support, precise alignment in case of direct coupling and use of thread sizes specified in EN 50347 for motor feet and flange mounting.
- Provide a vibration-free environment. Avoid build-up resonances with rotation frequency and the double frequency of the power supply.
- Turn the rotor by hand, pay attention to unusual grinding noises. Check the direction of rotation in the coupled state.
- Pull the drive elements (belt pulley, clutch etc.) on and off using only suitable devices. Use cover to protect from touching. The part to be pulled on is to be heated. Transmission elements must not be hammered on the shaft by force. Avoid excessive belt tension.
- Airflow must not be prevented. Ensure enough space for the airflow and that the blown-out, heated cooling air is not drawn in back again.
- All components mounted on the shaft end must be carefully balanced. The standard motors are half-key balanced unless explicitly specified.
- Due to the use of cylindrical roller bearings („reinforced NU-Bearing“) relatively high radial forces or masses can be applied at the end of the motor shaft. The minimum radial force at the shaft end must be a quarter of the permissible radial force. The permissible shaft load must be taken into account.
- The user ensures that the condensate water drain holes on motors with increased IP protection (IPX6 / IP6X) are sealed in a water – or dust-tight manner after the condensate has been drained as well as during transport and storage.
- For the IM B14 and IM B34 mounting motors the maximum screw-in depths specified in the table 1 must be observed. If an IM B14 and IM B34 mounting motor is used, stored or transported without flanged equipment, the user must take appropriate precautions against the intrusion of foreign particles and moisture through the threaded holes.

Frame size	Screw-in depth, mm	Frame size	Screw-in depth, mm
56-63	8	100-112	15
71	10	132	17
80	11	160	24
90	14		

Table 1. Screw-in depths of motor mountings IM B14 and IM B34.

5. Electrical connection

5.1. General information

All maintenance procedures must only be carried out by a qualified specialist on a stationary motor in a state where it is disconnected and secured against restart. This also applies to auxiliary circuits (heating). Please note the performance data on the nameplate and connection diagram in the terminal box.

Caution: follow the performance data on the motor nameplate.

According to IEC / EN 60034-1 (VDE 0530-1) for the operation of asynchronous standard motors, voltage deviations of up to $\pm 5\%$ are permissible. Power supply cables should be selected according to the installation specific conditions specified in DIN VDE 0100 (current, ambient temperature, installation method etc.).

The connection must be made in such a way that a permanently secure electrical connection is maintained (no protruding wire ends). Suitable cable lugs must be used for the connections of all main cables. A safe protective conductor connection must be made. Tightening torques can be found in Table 2.

Thread	Frame size	Tightening torque (Nm)	
		Min.	Max.
M4	BG56-80	1,9	2,2
M5	BG90-132	3,9	4,5
M6	BG160-180	6,6	7,5
M8	BG200-225	16,0	18,4
M10	BG250-280	32,0	36,0
M12	BG315 (only AWM)	68,0	74,0
M16	BG315, BG355 (only AWM)	139,0	159,0
M20	BG355, BG400 (only AWM)	273,0	312,0
M24	BG400	472,0	539,0

Table 2. Tightening torques for cable connection.

Caution: ensure the appropriate selection of the power supply cables.

There must be no foreign bodies, dirt, or moisture in the terminal box. Close unused cable entry openings and the terminal box so that they are dust- and watertight. For the test run without drive elements, secure the feather key against being thrown out.

5.2. Connection of lead out cables

For motors with lead out cables, the terminal board is dismantled at the factory and the connecting leads are connected to the terminals of the stator winding. The connection leads are colour-coded, the assignment of the colour is glued on the cover plate. For the motor version with terminal box, each individual wire is labeled. The user connects the lead out cables in the control cabinet accordingly.

6. Commissioning

6.1. General information

The installation must be carried out in a power-supply-free state, in accordance with applicable regulations by appropriately trained personnel. The nameplate data of the motor must be compared to the power supply conditions. The dimensions of the power cables must be adapted to the nominal currents of the motor. The motors are to be operated with an overcurrent protection, which is adjusted according to the rated data (1.1 times rated current) of the motor. Failure to do so leads to the winding defect and a loss of warranty.

Caution: check the insulation resistance of the winding before commissioning.

Please check the insulation resistance of the winding before switching it on for the first time. The resistance should be higher than 5MΩ at an ambient temperature of 25°C. After longer storage, the insulation test must also be carried out. Before the machine is connected, the direction of rotation must be checked. If necessary, change the direction of rotation by exchanging the connection of two phases.

Before closing the terminal box it is essential to check that:

- The connection is done according to the connection diagram
- All terminal box connections, mounting parts and grounding connections are firmly tightened
- Auxiliary devices are functional
- All minimum values of the clearance distances between bare, voltage-carrying parts towards the ground and to each other (10mm bus 750V) are complied with
- Unused cable entry openings and the condensate drain (if present) are sealed dust-tight and water-tight.

When commissioning, it is advisable to observe the current consumption under load in order to recognize any possible overload or asymmetries on the line.

6.2. Tightening torques

Table 3 shows tightening torques for screws of the end shields, bearing caps and terminal box.

Frame size	Arrangement	End shield	Bearing cap	Terminal box cap	Terminal box
Thread / Tightening torque (Nm)					
56	B3/B5/B14	M4 / 2,0 Nm	-	M4 / 1,0 Nm	M4 / 2,0 Nm
63			-	M5 / 1,5 Nm	M5 / 3,0 Nm
71			-		
80		M6 / 7,0 Nm	-	M5 / 2,5 Nm	M5 / 4,0 Nm
90			-		
100		M8 / 17 Nm	-	M6 / 3,0 Nm	M6 / 4,5 Nm
112			-		
132			-		
160		M10 / 34 Nm	M6 / 7 Nm	M8 / 4,0 Nm	M8 / 7,0 Nm
180			M8 / 17 Nm		
200		M12 / 60 Nm		M10 / 34 Nm	M8 / 4,5 Nm
225			M10 / 5,5 Nm		M10 / 12,5 Nm
250			M16 / 149 Nm		M12 / 7,0 Nm
280					
315		M20 / 290 Nm			
355					
400					

Table 3. Tightening torques for terminal box, end shield and bearing cap.

If a motor has an arrangement on feet (type B3, B34, B35), the following tightening torques for the screws on the motor feet must be complied with:

Thread	Tightening torque (Nm) Min.	Tightening torque (Nm) Max.
M4	2,0	3,0
M5	3,5	5,0
M6	6,0	9,0
M8	16,0	24,0
M10	30,0	44,0
M12	46,0	70,0
M16	110,0	165,0
M20	225,0	340,0

Table 4. Tightening torques for motor feet screws.

Tightening torques for the metal and plastic cable glands for the direct attachment to the machine and other glands (such as reducers) shall be in accordance with **Table 5**.

Cable gland	Metal $\pm 10\%$ Nm	Plastic $\pm 10\%$ Nm
M16 x 1,5	10	2
M20 x 1,5	12	4
M25 x 1,5		
M32 x 1,5	18	6
M40 x 1,5		
M50 x 1,5	20	
M60 x 1,5		

Table 5. Tightening torques for cable glands.

7. Maintenance

Maintenance of the motor may only be conducted considering the safety instructions in 1 – 6. Careful and regular maintenance, inspections and revisions are necessary in order to detect and correct any faults in good time before damage can occur. General deadlines are given in the **Table 6** below (periods should be adapted to the local conditions, such as pollution, load etc.):

Function	Time interval	Periods
Initial inspection	After approx. 500h	At the latest after ½ year
Control of the airways and surface of the motor	Depending on local conditions	
Re-lubrication	Acc. Table 7 or nameplate	Once a year
Main inspection	10.000 h	Once a year

Table 6. Notifiable maintenance and inspections.

A grease quality allows the operation of the engine of the motors of 20.000 h without renewal of the rolling bearing grease under normal load conditions and under normal environment conditions. The condition of grease should however be controlled even during this period. The specified life expectancy of bearings applies only for operation with nominal speed and bearing operating temperature of 80°C (ambient temperature 20°C). When operating with inverter or increased ambient temperatures, the specified lubrication periods must be reduced by 25% as a result of the higher heating of the motor. If the nominal speed is exceeded during the operation of the motor with inverter, the re-lubrication periods are reduced in the reverse proportion to the increase in the speed. Re-lubricate the bearings after thorough cleaning with appropriate solvents.

Caution: when operating over the rated speed or at increased ambient temperatures, the specified lubrication periods must be reduced by 25%.

The greases with the same oil base and the same thickener must be used. The grease quantity indicated on the nameplate must be observed. Approximately twice the quantity is required for the first relubrication, as the grease lubrication tubes are still empty. The used old grease must be disposed of after 3 relubrication operations.

7.1. Initial inspection

Following tests are carried out when the machinery is at downtime:

- Check the foundation.

Following tests are carried out when the machinery is running:

- Check the electrical characteristics.
- Check the bearing temperatures.
- Check the running noise.

7.2. Main inspection

The following tests are carried out when the machine is at a standstill:

- Check the foundation.
- Check the alignment of the motor.
- Check the fastening screws and tightening torques
- Check the cables and the insulation material. The test determines whether the cables and the insulating materials are in a proper condition. They must not display discoloration or any burn marks and must not be cracked or otherwise damaged.
- Check the insulation resistance
- Depending on the quality of grease, local ambient conditions and the duty, the change of the rolling bearings and the oil seals may be necessary after 10.000 h (but at least annually).

The following tests are carried out when the machine is running:

- Check the electrical characteristics
- Check the bearing temperatures
- Check the running noise

All discrepancies discovered during the inspections must be rectified immediately.

7.3 Lubrication

For motors with open rolling bearings (current-insulated or "reinforced" NU bearings), the relubrication intervals must be observed in accordance with the table shown .

*= For motors of size 56 to 180, closed bearings with lifetime lubrication are used!

Type	Power	Pole	Ball bearing (A-Side) Bearing clearance:C3	Ball bearing (B-Side) Bearing clearance:C3	Re-Lubrication- Intervalls Hours	First - Filling DE/NDE Gram	Re-Lubrication- Quantity DE/NDE Gram
SEV-160M2	11	2	6209	6209	*	*	*
SEV-160Mx-2	15	2	6209	6209	*	*	*
SEV-160L2	18,5	2	6209	6209	*	*	*
SEV-180M2	22	2	6211	6211	*	*	*
SEV-200L2	30	2	6212 / NU312	6212	1500	32/32	25/25
SEV-200Lx-2	37	2	6212 / NU312	6212	1500	32/32	25/25
SEV-225M2	45	2	6312 / NU312	6312	1500	32/32	25/25
SEV-250M2	55	2	6313 / NU313	6313	1000	45/45	35/35
SEV-280S2	75	2	6314 / NU314	6314	1000	45/45	35/35
SEV-280M2	90	2	6314 / NU314	6314	1000	45/45	35/35
SEV-315S2	110	2	6317 / NU317	6317	1000	65/65	50/50
SEV-315M2	132	2	6317 / NU317	6317	1000	65/65	50/50
SEV-315L2	160	2	6317 / NU317	6317	1000	65/65	50/50
SEV-315Lx-2	200	2	6317 / NU317	6317	1000	65/65	50/50
SEV-355M2	250	2	6319 / NU319	6319	1000	80/80	60/60
SEV-355L-2	315	2	6319 / NU319	6319	1000	80/80	60/60
SEV-160M4	11	4	6309	6209	*	*	*
SEV-160L4	15	4	6309	6209	*	*	*
SEV-180M4	18,5	4	6311	6211	*	*	*
SEV-180L4	22	4	6311	6211	*	*	*
SEV-200L4	30	4	6312 / NU312	6212	5000	32/32	25/25
SEV-225S4	37	4	6313 / NU313	6312	5000	32/32	25/25
SEV-225M4	45	4	6313 / NU313	6312	5000	32/32	25/25
SEV-250M4	55	4	6314 / NU314	6313	4500	45/45	35/35
SEV-280S4	75	4	6317 / NU317	6314	4000	45/45	35/35
SEV-280M4	90	4	6317 / NU317	6314	4000	45/45	35/35
SEV-315S4	110	4	6319 / NU319	6319	3500	65/65	50/50
SEV-315M4	132	4	6319 / NU319	6319	3500	65/65	50/50
SEV-315L4	160	4	6319 / NU319	6319	3500	65/65	50/50
SEV-315Lx-4	200	4	6319 / NU319	6319	3500	65/65	50/50
SEV-355M4	250	4	6322 / NU322	6322	2800	80/80	60/60
SEV-355L4	315	4	6322 / NU322	6322	2800	80/80	60/60

Table 7. Relubrication intervals for open and reinforced bearings

Type	Power	Pole	Ball bearing (A-Side) Bearing clearance:C3	Ball bearing (B-Side) Bearing clearance:C3	Re-Lubrication- Intervalls Hours	First - Filling DE/NDE Gram	Re-Lubrication- Quantity DE/NDE Gram
SEV-160M6	7,5	6	6309	6209	*	*	*
SEV-160L6	11	6	6309	6209	*	*	*
SEV-180L6	15	6	6311	6211	*	*	*
SEV-200L6	18,5	6	6312 / NU312	6212	6500	32/32	25/25
SEV-200Lx-6	22	6	6312 / NU312	6212	6500	32/32	25/25
SEV-225M6	30	6	6313 / NU313	6312	6500	32/32	25/25
SEV-250M6	37	6	6314 / NU314	6313	6300	45/45	35/35
SEV-280S6	45	6	6317 / NU317	6314	6000	45/45	35/35
SEV-280M6	55	6	6317 / NU317	6314	6000	45/45	35/35
SEV-315S6	75	6	6319 / NU319	6319	5800	65/65	50/50
SEV-315M6	90	6	6319 / NU319	6319	5800	65/65	50/50
SEV-315L6	110	6	6319 / NU319	6319	5800	65/65	50/50
SEV-315Lx-6	132	6	6319 / NU319	6319	5800	65/65	50/50
SEV-355M6	160	6	6322 / NU322	6322	4800	80/80	60/60
SEV-355Mx-6	200	6	6322 / NU322	6322	4800	80/80	60/60
SEV-160M1-8	4	8	6309	6209	*	*	*
SEV-160M2-8	5 5	8	6309	6209	*	*	*
SEV-160L-8	7 5	8	6309	6209	*	*	*
SEV-180L-8	11	8	6311	6211	*	*	*
SEV-200L-8	15	8	6312 / NU312	6212	6500	32/32	25/25
SEV-225S-8	18 5	8	6313 / NU313	6312	6500	32/32	25/25
SEV-225M-8	22	8	6313 / NU313	6312	6500	32/32	25/25
SEV-250M-8	30	8	6314 / NU314	6313	6300	45/45	35/35
SEV-280S-8	37	8	6317 / NU317	6314	6000	45/45	35/35
SEV-280M-8	45	8	6317 / NU317	6314	6000	45/45	35/35
SEV-315S-8	55	8	6319 / NU319	6319	5800	65/65	50/50
SEV-315M-8	75	8	6319 / NU319	6319	5800	65/65	50/50
SEV-315L1-8	90	8	6319 / NU319	6319	5800	65/65	50/50
SEV-315L2-8	110	8	6319 / NU319	6319	5800	65/65	50/50
SEV-355M1-8	132	8	6322 / NU322	6322	4800	80/80	60/60
SEV-355M2-8	160	8	6322 / NU322	6322	4800	80/80	60/60
SEV-355M3-8	180	8	6322 / NU322	6322	4800	80/80	60/60
SEV-355L-8	200	8	6322 / NU322	6322	4800	80/80	60/60

Table 7. Relubrication intervals for open and reinforced bearings

Table 7.1 Ball bearings IP23 Motors

Size	Ball bearings IP23					
	2 pole		4 pole		6 pole	
	DE	NDE	DE	NDE	DE	NDE
160	6310 C3	6309 C3	6310 C3	6309 C3	6310 C3	6309 C3
180	6312 C3	6312 C3	6312 C3	6312 C3	6312 C3	6312 C3
200	6313 C3	6313 C3	6313 C3	6313 C3	6313 C3	6313 C3
225	6314 C3	6314 C3	6314 C3	6314 C3	6314 C3	6314 C3
250	6314 C3	6314 C3	6317 C3	6317 C3	6317 C3	6317 C3
280	6314 C3	6314 C3	6318 C3	6318 C3	6318 C3	6318 C3
315	6317 C3	6317 C3	6319 C3	6319 C3	6319 C3	6319 C3
355	6317 C3	6317 C3	6322 C3	6320 C3	6322 C3	6320 C3

Table 7.1 Ball bearings IP23

Re-greasing on a running machine as well as downtime re-greasing is possible. Following information should be noted:

- When the motor is running, make sure that the grease outlet, grease inlet, and channel are open. Inject the intended amount of grease into the bearing and let the machine run for 1 – 2 hours. Close the plug of the grease outlet. There may be a temporary increase in temperature of the bearing for the next 10 hours.
- When the motor is at a standstill, only half of the relubricating grease quantity must be used at first. Then let the motor run for 1 hour. After the motor has been switched off, inject the rest of the specified relubricating grease quantity into the bearing. After 2 hours of running, close the grease outlet.

For re-lubrication only ball bearing / roller bearing suitable grease with following properties can be used:

	2-poles		4-poles		6-poles		8-poles	
	63XX.C3	NU3XX.C3	63XX.C3	NU3XX.C3	63XX.C3	NU3XX.C3	63XX.C3	NU3XX.C3
Basis oil	Mineral oil							
Thickener	Lithium soap	Mixed thickener	Lithium soap	Mixed thickener	Lithium soap	Mixed thickener	Lithium soap	Mixed thickener
Viscosity 40°C	68-100	100-150	100-150	150-220	150-220	≥220	150-220	≥220
Consistency	3							
Least continuous service temperature	-30 +120°C	-30 +140°C	-30 +120°C	-30 +140°C	-30 +120°C	-30 +140°C	-30 +120°C	-30 +140°C

Table 8. Selection of the re-lubrication grease.

Caution: use appropriate grease for re-lubrication.

Table 8 displays a grease specification and is only valid for ambient temperatures of – 30°C to +60°C, bearing temperature up to 110°C and operation with the rated speed. When operating above the rated speed, special high-speed greases may be used.

8. Auxiliary equipment

The motors are equipped with additional devices:

8.1. Thermal protection

To monitor the stator winding temperature PTC, PTO and PT100 can be used. For their connection, corresponding auxiliary terminals and circuits are provided in the main terminal box. If it is necessary to re-measure the cold resistance (at approx. 20 °C) of the sensor circuit, the measuring voltage must not exceed 2.5V DC.

8.2. Electromagnetic compatibility

The conformity of the motors as an independent unit with the EMC standards has been confirmed. The user of machinery is responsible for the fact that appropriate measures are taken to ensure that the devices or systems, in which the motors are integrated, as a whole comply with the relevant standards of the EMC. Each motor is supplied with the binding connection diagram according to which the connection must be made.

9. Troubleshooting

Table 9 addresses the causes of errors that may occur and the action to be taken. All procedures are only allowed to be carried out by qualified personnel using suitable tools and instruments. For further information please contact JS-Technik GmbH.

Failure	Cause	Actions
The machinery doesn't start	Overload	Reduce the load
	Wrong stator connection	Check the connection
	Fault power supply	Check that power supply complies with information on nameplate
	Interruption of one phase	Check connection and switches
	Mechanical fault	Check that motor rotates freely. Check the bearing and lubrication.
	Rotor defect	Check the broken bars and end rings.
	Fuses burnt	Use suitable fuses
The machinery is accelerating slow / doesn't accelerate	Load inertia at start too high	Reduce the load
	Under-voltage at motor terminals due to the voltage drop	Use higher voltage or higher transformer stage or reduce the load. Use appropriate cable cross-section.
	Defect rotor / broken rotor bars	Check the broken bars and end rings.
	Winding / phase short circuit	Motor overhaul is needed
Overheating of the machinery during operation with load	Overload	Reduce the load
	Cooling is prevented by dust accumulation	Ensure proper cooling and cleanliness
	Interruption of one phase	Check connection and switches
	Short circuit on the ground	Repair in workshop needed
	Imbalance of the power supply	Check the cables and transformer for faults
Motor vibrations	Wrong alignment	Align the motor
	Substructure is unstable	Reinforce substructure
	Imbalance in clutch / gearbox	Balance clutch / gearbox
	Imbalance in driven machinery	Re-balance the machinery system
	Defect bearing	Exchange the bearing
	Multi-phase motor runs single-phase	Check the circuit
Operation noise	Circulating parts grinding	Correct the mounting
	Winding / phase short circuit	Motor overhaul
	Interruption of one phase	Check connection and switches
High bearing temperature	Motor shaft bent or damaged	Straighten or replace the shaft
	Wrong belt drive	Reduce belt tension, arrange pulley closer to the bearing
	Wrong alignment	Align the machinery
	Inadequate / excess grease	Note the amount of re-grease

Table 9. Troubleshooting

10. Structure of the motors

Beschreibung Ersatzteile / description of spare parts

Aluminiumgehäuse / aluminum housing

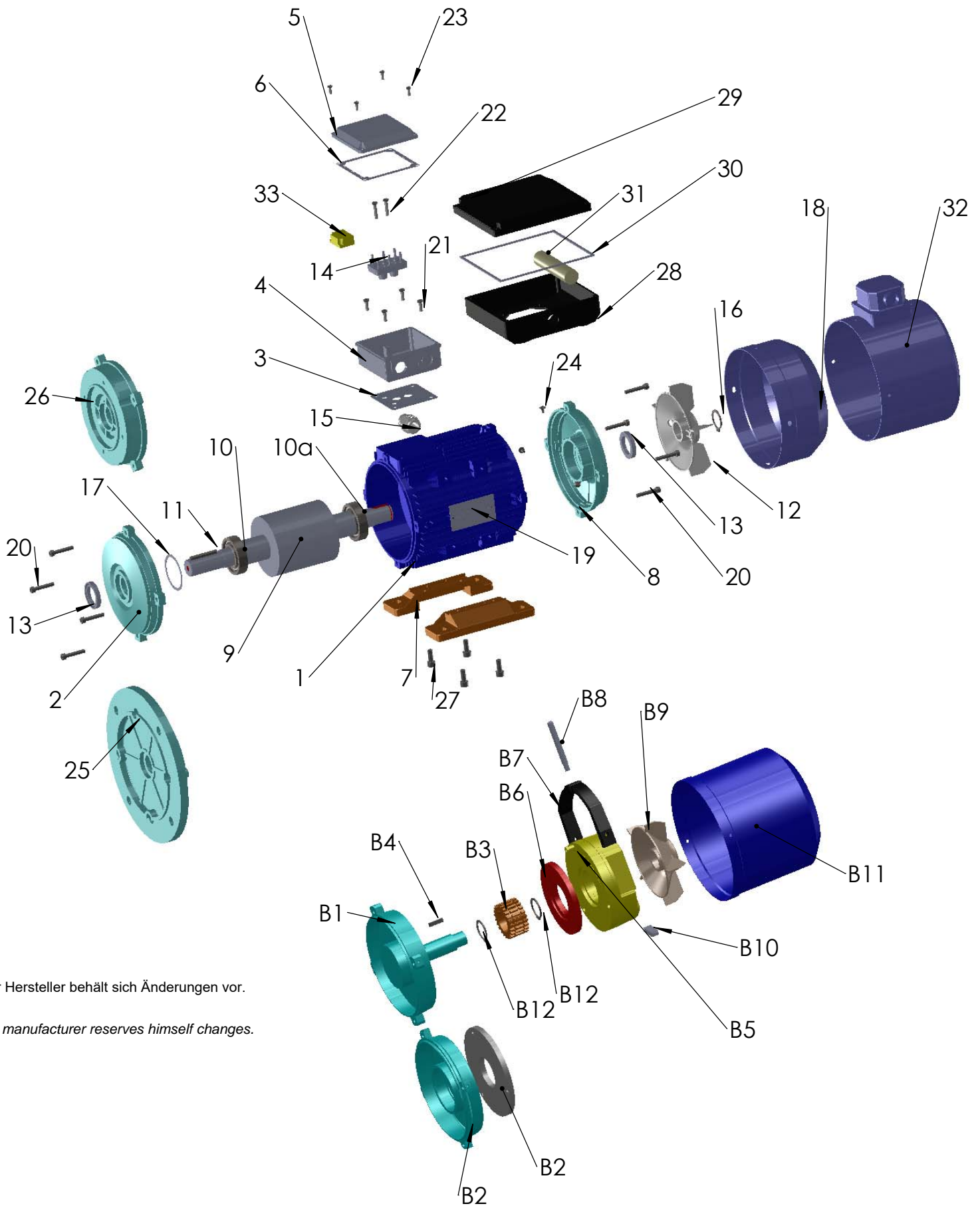

Der Hersteller behält sich Änderungen vor.

The manufacturer reserves himself changes.

Beschreibung Ersatzteile / description of spare parts
Aluminiumgehäuse / aluminum housing

No.	Bezeichnung	description	Serie MS	Serie ML
1	Statorgehäuse	Stator frame	X	X
2	A-Lagerschild	Drive end shield	X	X
3	Dichtung für Klemmenkasten	Gasket for terminal box	X	X
4	Klemmenkasten	Terminal box	X	
5	Klemmenkastendeckel	Terminal box cover	X	
6	Dichtung für Klemmenkastendeckel	Gasket for terminal box cover	X	
7	AnaufüÙe für Statorgehäuse	Mounting feet for stator	X	X
8	B-Lagerschild	Non drive end shield	X	X
9	Kurzschlussläufer	Squirrel-cage	X	X
10	DE-Lager	Drive end bearing	X	X
10a	NDE-Lager	Non drive end bearing	X	X
11	Passfeder	Key	X	X
12	Lüfterflügel	Fan	X	X
13	Wellendichtring	Dust seal	X	X
14	Klemmenbrett	Terminal board	X	X
15	Kabelverschraubung	Cable gland	X	X
16	Sicherungsring	Circlip	X	X
17	Lagerausgleichscheibe	Bearing shim	X	X
18	Lüfterhaube	Fan cover	X	X
19	Typenschild	Name plate	X	X
20	Schraube für Lagerschild bzw. Flansch	Screw for end shield	X	X
21	Schraube für Klemmenkasten	Screw for terminal box	X	X
22	Schraube für Klemmenbrett	Screw for terminal board	X	X
23	Schraube für Klemmenkastendeckel	Screw for terminal box cover	X	X
24	Schraube für Lüfterhaube	Screw for fan cover	X	X
25	B5 -Flansch	Flange IM B5	X	X
26	B14 - Flansch	Flange IM B14	X	X
27	Schraube für AnaufüÙe	Screw for mounting feet	X	X
28	Klemmenkasten	Terminal box		X
29	Klemmenkastendeckel	Terminal box cover		X
30	Dichtung für Klemmenkastendeckel	Gasket for terminal box cover		X
32	Kondensator	capacitor		X
32	Fremdlüfter	Force ventilation	X	X
Beschreibung Ersatzteile Bremsausführung Description Spare parts braking performance				
33	Gleichrichter	rectifier	X	X
B1	Bremslagerschild b-seitig (Grauguss)	Drive end shield for brake	X	
B2	B-Lagerschild mit Bremsflansch	Drive end shield with brake-flange	X	X
B3	Bremsnarbe	brake hub	X	X
B4	Passfeder	Key	X	X
B5	Bremse	Brake	X	X
B6	Bremsscheibe	Brake-flange	X	X
B7	Handlüftung	manual release	X	X
B8	Handlüftungshebel	Manual release lever	X	X
B9	Lüfterflügel	Fan	X	X
B10	Mikroschalter	Microswitch	X	X
B11	Bremslüfterhaube	Fan cover	X	X
B12	Sicherungsring	circlip	X	X

Beschreibung Ersatzteile / description of spare parts
Graugussgehäuse / Cast iron housing

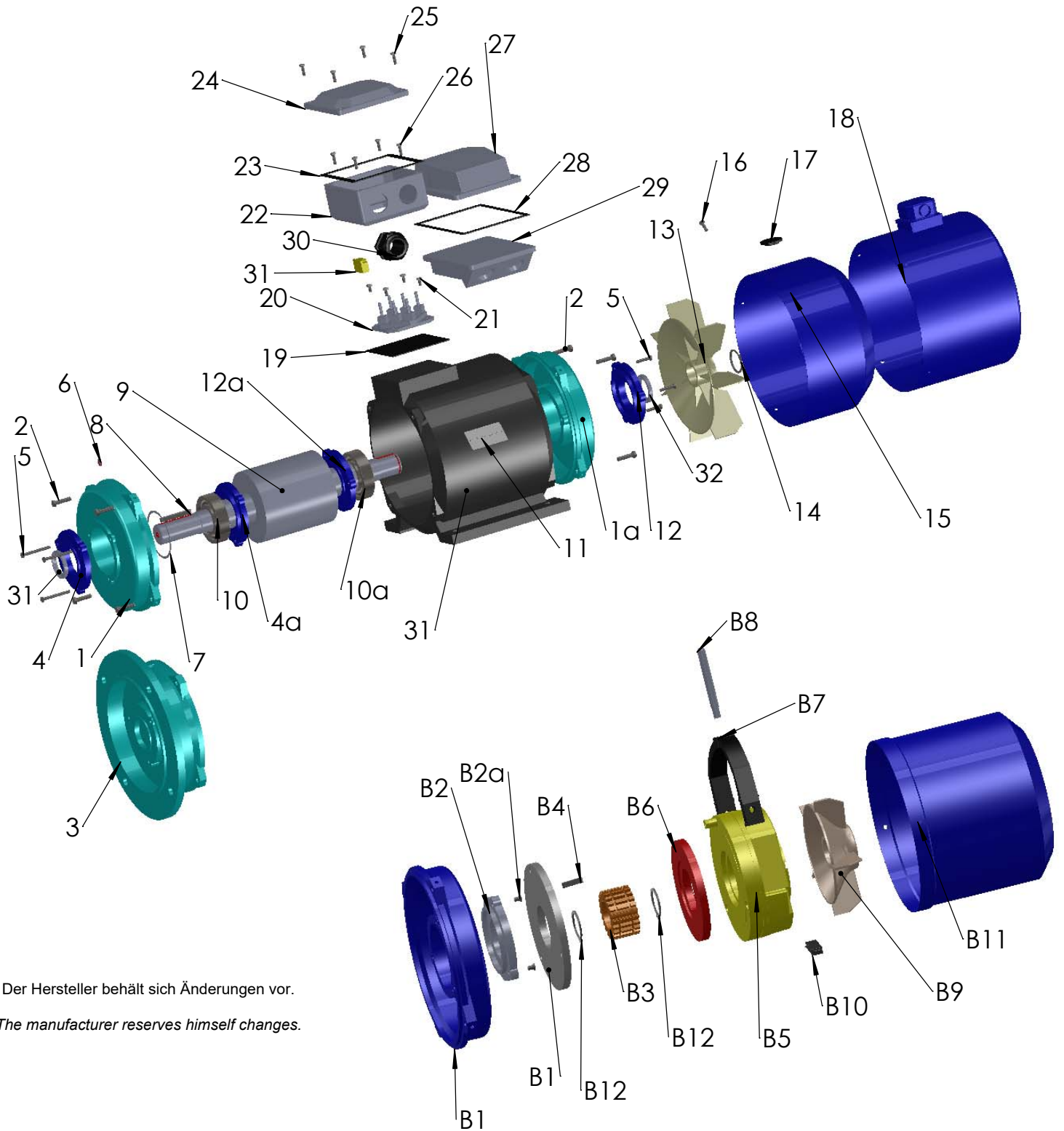

Der Hersteller behält sich Änderungen vor.
 The manufacturer reserves himself changes.

Beschreibung Ersatzteile / description of spare parts
Graugussgehäuse / cast iron housing

No.	Bezeichnung	description	Serie M	Serie MQ
1	A - Lagerschild	Drive end shield	X	X
1a	B – Lagerschild	Non drive end shield	X	X
2	Schrauben für Lagerschild bzw. Flansch	Screw for end shield	X	X
3	B5 – Flansch	Flange IM B5	X	X
4	DE - Lagerdeckel „außen“	Drive end outer bearing cap	X	X
4a	DE - Lagerdeckel „innen“	Drive end inner bearing cap	X	X
5	Schrauben für Lagerdeckel	Screw for drive end outer bearing cap	X	X
6	Schmiernippel	grease nipple	X	X
7	Lagerausgleichsscheibe	Bearing shim	X	X
8	Passfeder	Key	X	X
9	Kurzschlussläufer	Squirrel-cage	X	X
10	DE – Lager	Drive end bearing	X	X
10a	NDE – Lager	Non drive end bearing	X	X
11	Typenschild	Name plate	X	X
12	NDE - Lagerdeckel „außen“	Non drive end outer bearing cap	X	X
12a	NDE - Lagerdeckel „innen“	Non drive end inner bearing cap	X	X
13	Lüfterflügel	Fan	X	X
14	Sicherungsring	circlip	X	X
15	Lüfterhaube	Fan cover	X	X
16	Schraube für Lüfterhaube	Screw for fan cover	X	X
17	Stopfen für Lüfterhaube	Stopper for fan cover	X	X
18	Fremdlüfter	Force ventilation	X	X
19	Dichtung für Klemmenkasten	Gasket for terminal box	X	X
20	Klemmenbrett	Terminal board	X	X
21	Schraube für Klemmenbrett	Screw for terminal board	X	X
22	Klemmenkasten	Terminal box	X	
23	Dichtung für Klemmenkastendeckel	Gasket for terminal box cover	X	
24	Klemmenkastendeckel	terminal box cover	X	
25	Schraube für Klemmenkastendeckel	Screw for terminal box cover	X	X
26	Schraube für Klemmenkasten	Screw for terminal box	X	X
27	Klemmenkastendeckel	terminal box cover		X
28	Dichtung für Klemmenkastendeckel	Gasket for terminal box cover		X
29	Klemmenkasten	Terminal box		X
30	Kabelverschraubung	Cable gland	X	X
31	Statorgehäuse	Stator frame	X	X
Beschreibung Ersatzteile Bremsausführung Description Spare parts braking performance				
31	Gleichrichter	rectifier	X	X
B1	B – Lagerschild, inkl. Bremsflansch	Drive end shield with brake-flange	X	X
B2	NDE - Lagerdeckel „außen“	Non drive end outer bearing cap	X	X
B3	Bremsnarbe	brake hub	X	X
B4	Passfeder	Key	X	X
B5	Bremse	Brake	X	X
B6	Bremsscheibe	Brake-flange	X	X
B7	Handlüftung	manual release	X	X
B8	Handlüftungshebel	Manual release lever	X	X
B9	Lüfterflügel	Fan	X	X
B10	Mikroschalter	Microswitch	X	X
B11	Bremslüfterhaube	Fan cover	X	X
B12	Sicherungsring	circlip	X	X

11. Connection variants + Circuit diagrams

11.1 Three-phase motors

Pole Number	Nominal Powers at 400V, 50Hz	
	230V (D) / 400 V (Y)	400V (D)
2 or 4	≤ 3 kW	≥ 4 kW
6	≤ 2,2 kW	≥ 3 kW
8	≤ 1,5 kW	≥ 2,2 kW
Starting Principle	Direct	Direct or Y/D

Basic motor connection wiring diagram

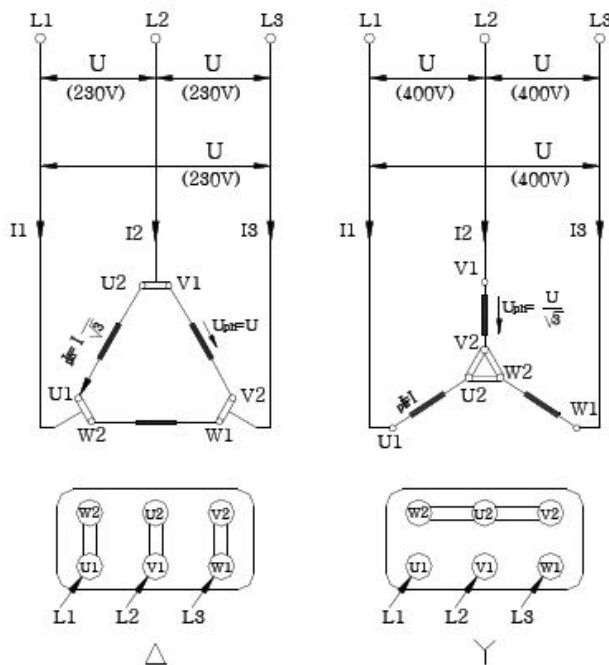

Delta connection



Star connection

11.2 Forced cooling fan

Variant 1

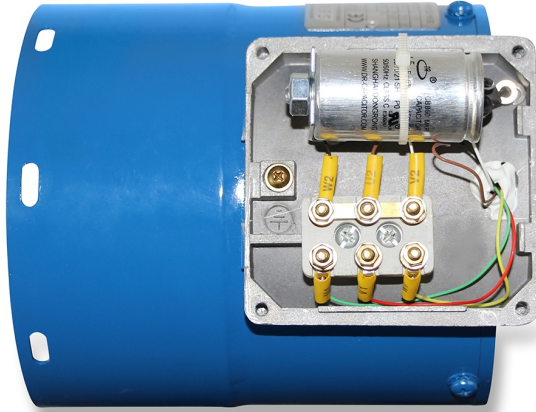

Multivoltage forced cooling fan, 230V masonry connection, 400V in star connection, in size 63 to 132, own connection cable required, cannot be operated via a frequency converter.

Variant 2



400V external fan in star connection, in sizes 160 to 315, own connection cable required, not to be operated via a frequency converter.

11.3 Brake motors - Brake rectifier

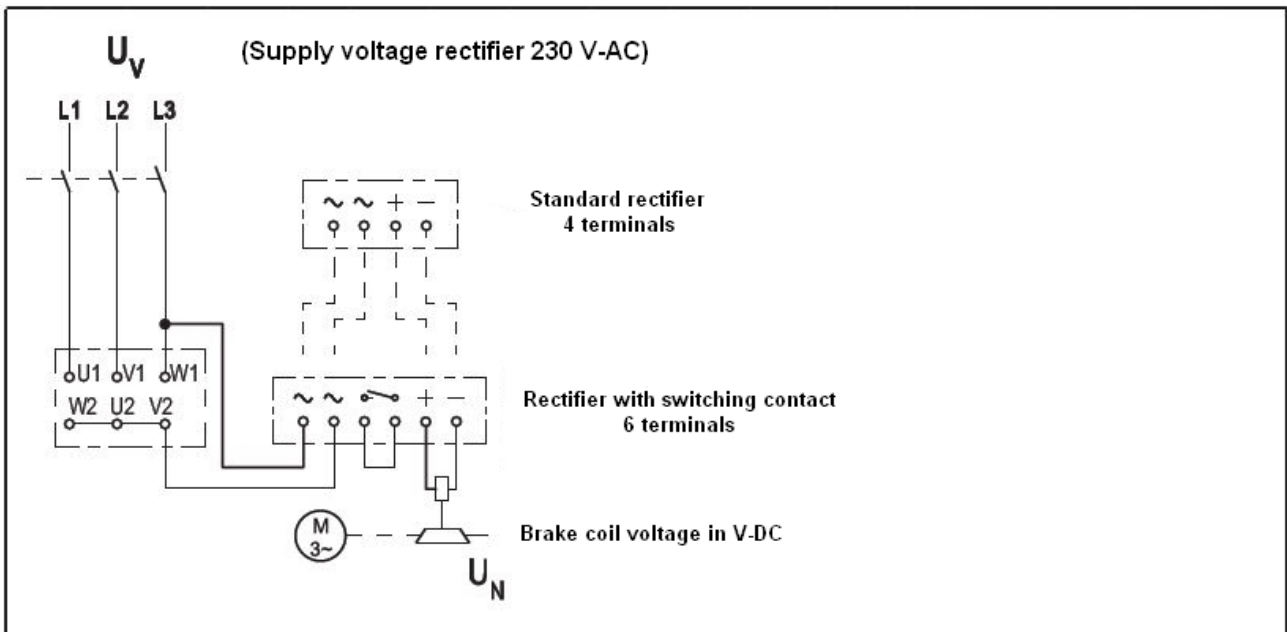

Supply: Phase-Starpoint

Bridge rectifier

$$U_N [\text{VDC}] = 0.9 \cdot U_V [\text{VAC}]$$

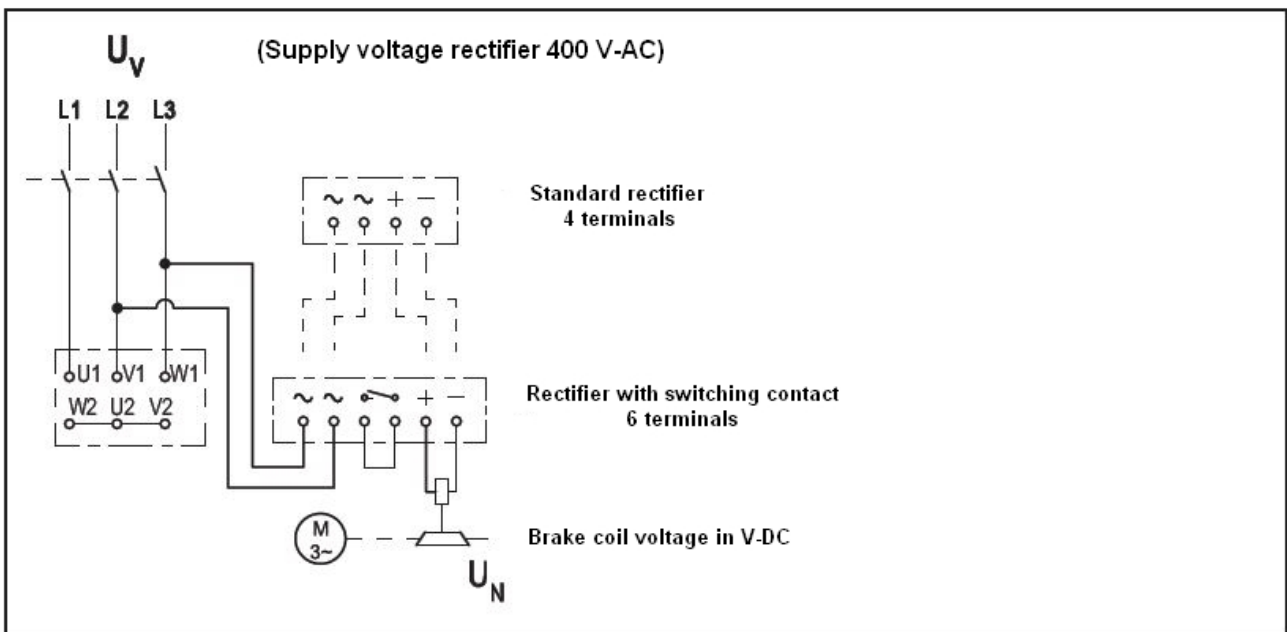

Supply: Phase-Phase

Half-wave rectifier

$$U_N [\text{VDC}] = 0.45 \cdot U_V [\text{VAC}]$$

11.4 Pole changing motors

Dahlander circuit for motors with two speeds and constant torque (number of poles: 4/2, 8.4).

Low speed

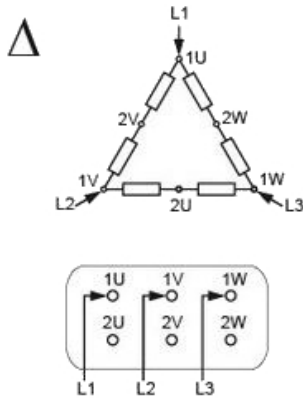

High speed

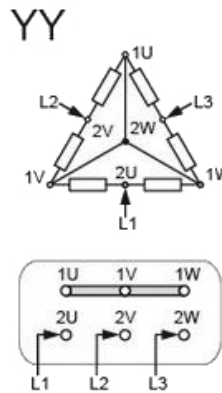

Dahlander circuit for motors with two speeds and quadrature torque (number of poles: 4/2, 8.4).

Low speed

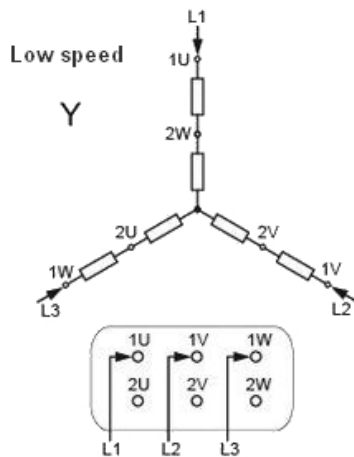

High speed

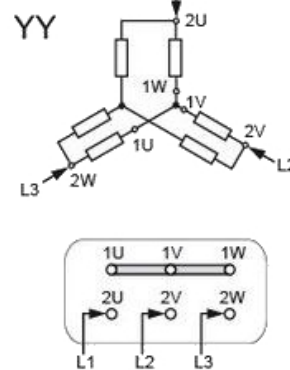

Circuit for motors with two speeds and two separate windings (number of poles: 6/4, 8/2, 6/2).

Low speed

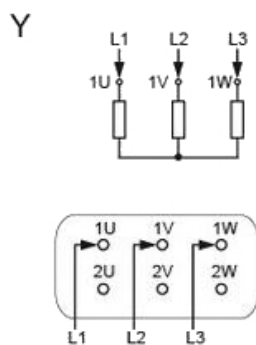

High speed

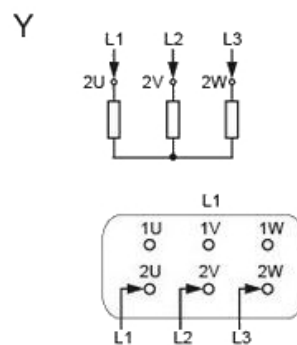

12. Motor Behaviour in Frequency Converter Operation

- Load capacity curve of electric motors in frequency converter operation without forced cooling fan.

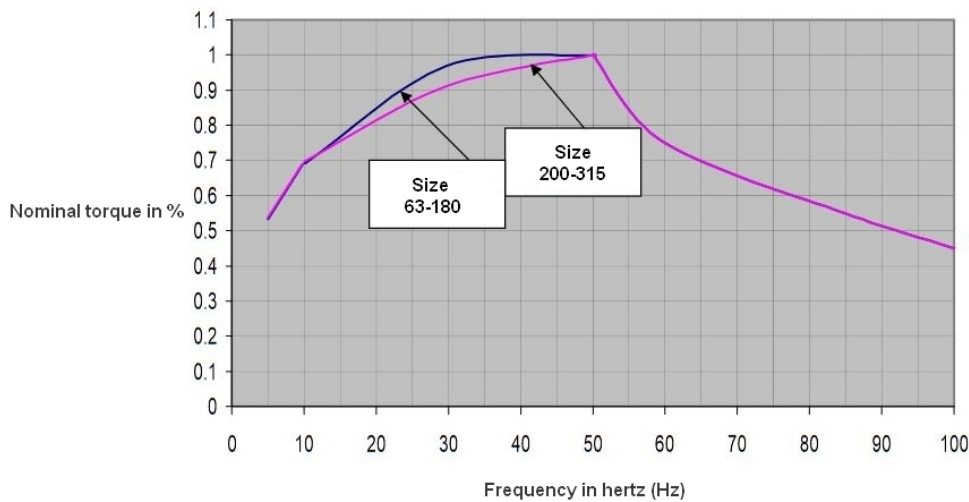

- The minimum frequency is approximately 5 Hz, the recommended maximum frequency is approximately 100 Hz.
- A forced cooling fan must be used for the electric motor for continuous operation at less than 30 Hz.

12.1 Explanation of the 87 Hz Characteristic Curve

Electric motors can also be controlled by an 87 Hz characteristic curve when constant torque at high speed is required.

Example:

An electric motor with 1.5kW, 230/400V D/Y, 50 Hz, 1430 rpm, 3.21 A in star connection is reconnected to delta connection. The coil voltage is then $3 \times 230V$ but is designed for $3 \times 400V$. The three-phase frequency converter reaches this at 87 Hz.

The motor data described above is thus multiplied by a factor of $3 \sqrt{3}$ (1.73). They increase to 2.6kW, 400V, 2474 rpm and 5.55 A at a constant torque of 87 Hz. This means that the frequency converter must be adapted to the higher amperage. For this application, at least a 1- or even 2-series larger frequency inverter will have to be used.

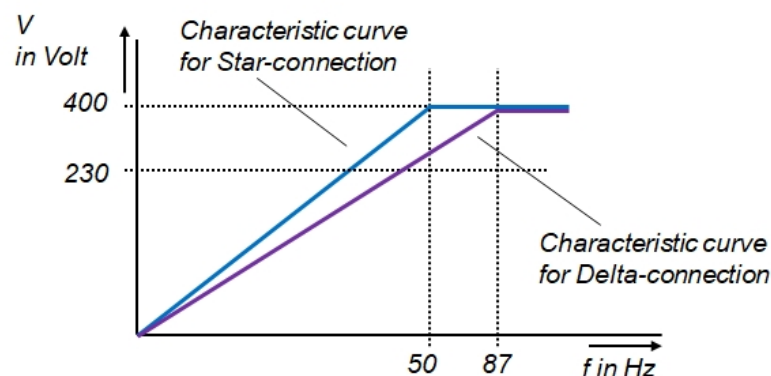

Important Notice:

Usage at above 50 Hz should be for short time periods only. Due to increased mechanical losses and the resulting higher thermal load, the use of a next greater three-phase motor is recommended.

EU Declaration of Conformity

Manufacturer: JS-Technik GmbH
Lether Gewerbestrasse 10
Address: 26197 Großenkneten

Product name: **Low voltage asynchronous motors,
single phase motors, gear motors**

1) Motors that comply with Guideline VO (EU) 2019/1781 and Regulation (EU) No. 4/2014 are given the identifier IEx-, before the series designation where x = 1,2,3,4 (according to EN 60034-30-1:2014).

The subject matter of the declaration described above complies with the relevant EU harmonisation legislation:

2014/35/EU

**Directive of the European Parliament and of the Council of 26 February 2014 on the harmonisation of the laws of the Member States relating to the making available on the market of electrical equipment designed for use within certain voltage limits
Official Journal of the European Union L96, 29.03.2014, S. 357-374**

2014/30/EU

**Directive of the European Parliament and of the Council of 26 February 2014 on the harmonisation of the laws of the Member States relating to electromagnetic compatibility
Official Journal of the European Union L96, 29.03.2014, S. 79-106**

2019/1781/EC

**Directive of the European Parliament and of the Council of 1 October 2019 establishing a framework for the setting of ecodesign requirements for energy-related products
Official Journal of the European Union EU L272/74, 25.10.2019, S. 10-18**

The sole responsibility for issuing this Declaration of Conformity lies with the manufacturers.

Compliance with the provisions of these Directives is demonstrated by compliance with the following standards:

Reference number and issue date

EN 61000-6-2:2005+Cor.:2005, EN 61000-6-4:2007+A1:2011

EN 60038:2011, EN 60204-1:2018

EN 60034-1 :2010+Cor.:2010 and all other relevant parts and additions EN 60034- ...

The specified product is intended for incorporation into another machine. Commissioning is prohibited until the conformity of the final product with Directive 2006/42/EC has been established. The safety instructions in the supplied product documentation must be observed.

Ahlhorn, 8.02.2024



Joachim Schulz
Managing Director

This certificate attests the conformity with the named directives; however, it is not a promise of properties in the meaning of product liability. In case of electronic communication, the signature does not appear.