

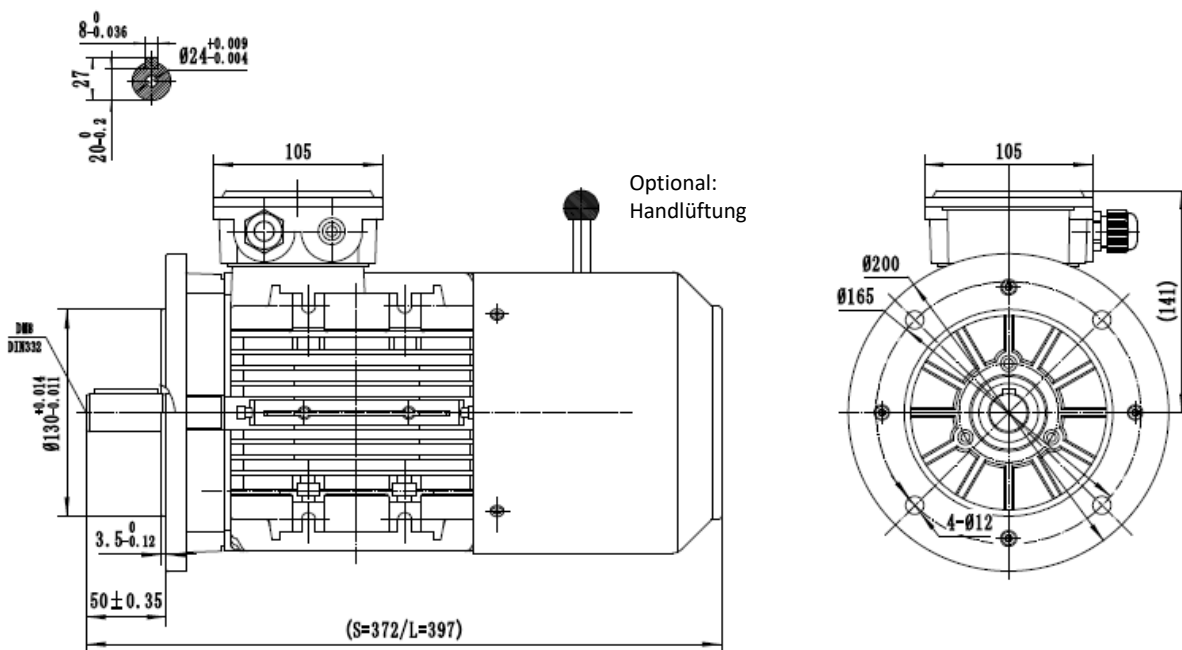

Drehstrombremsemotor / Three-Phase-Brakemotor

IE3 - 1,1 kW - 6 polig / 6 pole B5



Typ / type **SEV-BM3 90L-6**

Gehäusematerial / frame material		Aluminum	Nenn Drehmoment / rated torque	11,06
Ausführung / execution		Dreiphasen/ three phase	Anzugs- zu Nennmoment / start- to rated torque	2,7
Baugröße / frame size		90	Kipp- zu Nennmoment / brakedown- to rated torque	2,9
Leistung / power @50Hz	kW	1,10	min. Dreh- zu Nennmoment / min- to rated torque	2,5
Nennstrom / rated current @230V	Δ	5,07	Anzugs- zu Nennstrom / starting- to rated current	5,2
Nennstrom / rated current @400V	Y	2,93	Lager / bearing (DE)	6205-2RZ
Drehzahl / speed @50Hz	(r/min)	950	Lager / bearing (NDE)	6205-2RZ
Wirkungsgrad / efficiency	IE3		Wellendichtung / shaft seal (DE/NDE)	25x37x7
	Eff. 100%	81,00	Hauptkabelverschraubung / main cable glands	1-M20*1.5
	Eff. 75%	81,10	Isolationsklasse / insulation class	F
	Eff. 50%	78,40	Schutzart / protection degree	IP 55
Leistungsfaktor / power factor cosφ	100% load	0,67	Thermischer Schutz / thermal protection	3*PTC
60Hz 265/460V	Power(kW)	1,27	Drehrichtung / rotation direction	rechts-links / clockwise-counterclockwise
60Hz 276/480V	Power(kW)	1,32	Einschaltdauer / service duty	S1
Drehzahl / speed @60Hz	(r/min)	1140	Wuchtung / balance	Halbkeilwuchtung / half-key balanced
Ausführung Bremse / execution brake		BLC457-10	Kühlungsart / cooling	IC 411
Bremsmoment / braking torque (@ 100 Upm / rpm)		23	Lautstärke / noise dB(A)	59
Normen / regulations		IEC / DIN / ISO / VDE / EN	Nettogewicht / net weight(kg)	20,54
Standard / standard		IEC 60034	Massenträgheitsmoment / moment of inertia (kg*m ²)	0,005487386
Umgebungstemperatur / ambient Temp.		-20°C ~ +40°C	Aufstellungshöhe / altitude (max.)	1000m über Meeresspiegel / above sea level